



48V INPUT, 2000W

CPIM



PS2317 DC FILTER FEATURES

INPUT:	-36 to -72 VDC Input
INPUT CONNECTION:	2 Terminal block, 3 position
PASS THROUGH POWER:	2000 W
OUTPUT CONNECTOR:	Elcon Connector
PASS THROUGH:	- 48V @ 42A
NOMINAL SIZE:	7.4" x 2.5" x 5.3"
WEIGHT:	< 4 lbs.
COOLING:	External cooling (System cooling).
OPERATING AMBIENT:	-5 to +55°C
SIGNALS / CONTROLS:	Power OK Signal, Lamp Test Input
INDICATORS:	Input OK LED, CB Open LED, Output ON LED (CB Closed)
PROTECTIONS:	Reverse polarity protection (-48V INLINE diode), CB overcurrent protection
CONTROL:	Remote OFF.

MECHANICAL

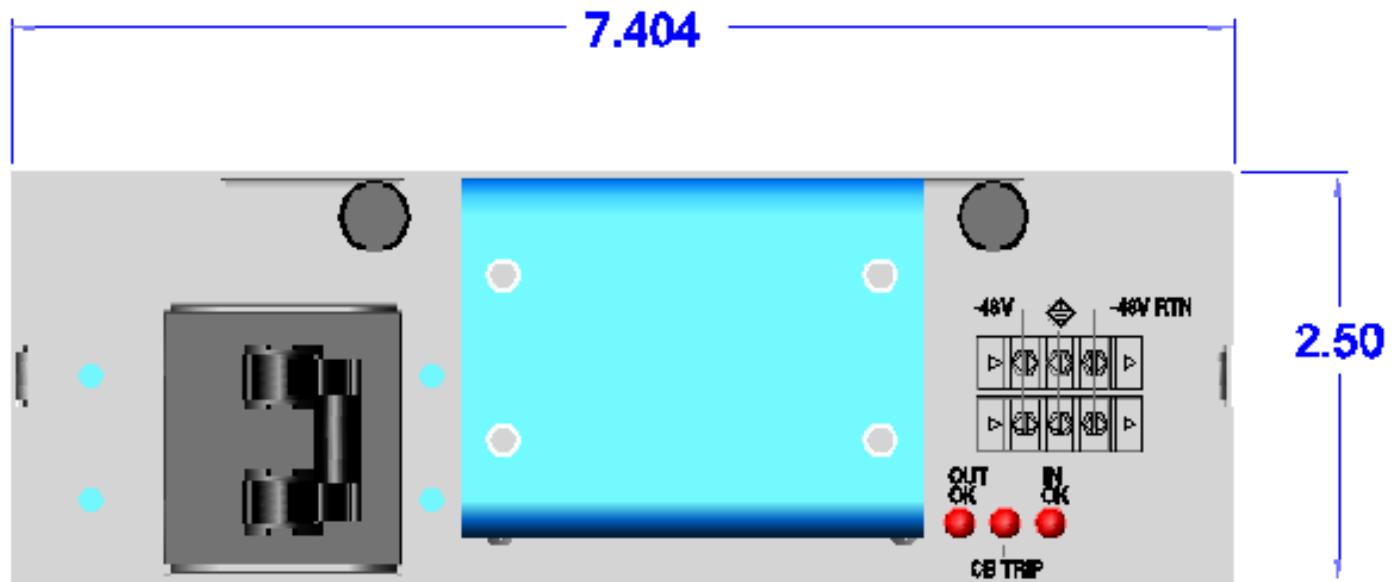

MECHANICAL

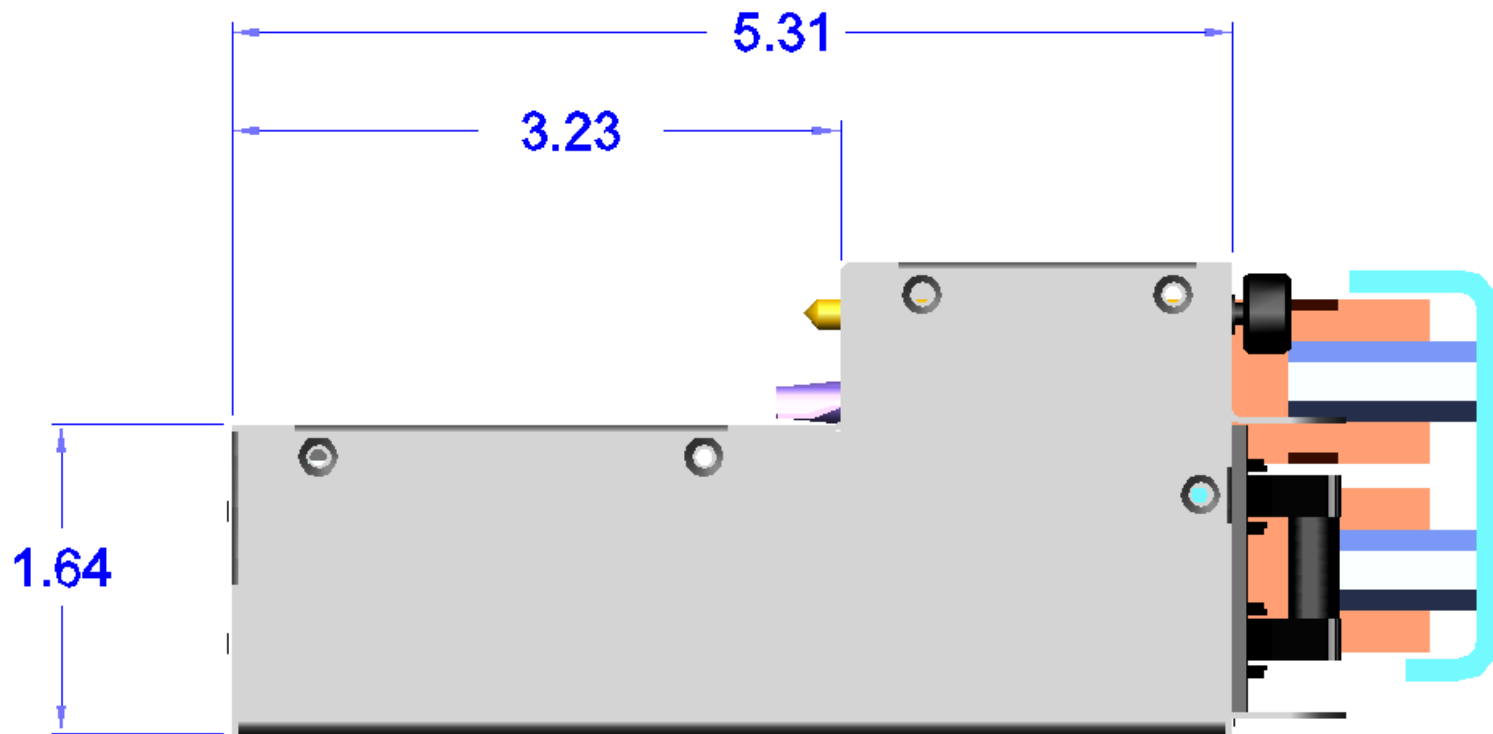

MECHANICAL

